

# VC.692-SST-p

Lobe knobs



ELESA Original design



INOX  
Stainless Steel

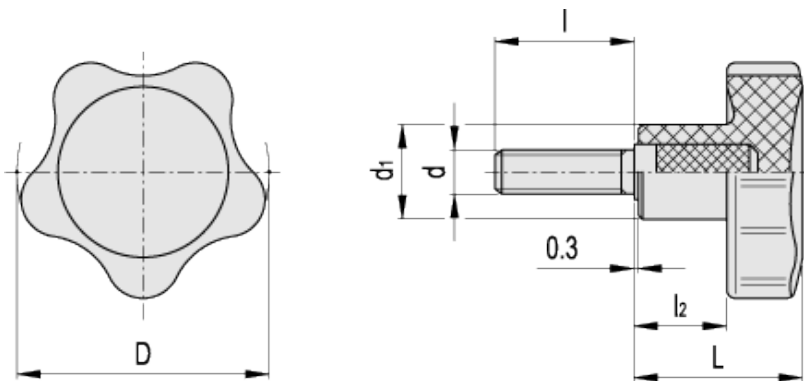

## technical informations

### Material

Glass-fibre reinforced polyamide based (PA) technopolymer. Resistant to solvents, oils, greases and other chemical agents.

### Colour

Black, matte finish.

### Standard execution

AISI 303 stainless steel threaded stud, chamfered flat end according to UNI 947 : ISO 4753 (see [Technical Data](#) ).

### Features and applications

The exclusive five-lobe shape (ELESA original design) offers the operator's fingers a proper grip and prevents unhealthy residues from depositing thanks to its solid shape without cavities.

This knob is particularly suitable for applications on machines and equipment whose parts, for hygienic reasons, must be frequently cleaned also using water or steam jets.

Standard Elements

Main dimensions

Threaded stud

Weight

| Code   | Description            | D  | L    | d <sub>1</sub> | l <sub>2</sub> | d <sub>6g</sub> | l  | g  |
|--------|------------------------|----|------|----------------|----------------|-----------------|----|----|
| 166157 | VC.692/25 SST-p-M4x6   | 25 | 20   | 12             | 10             | M4              | 6  | 6  |
| 166158 | VC.692/25 SST-p-M4x10  | 25 | 20   | 12             | 10             | M4              | 10 | 7  |
| 166161 | VC.692/25-SST-p-M5x10  | 25 | 20   | 12             | 10             | M5              | 10 | 8  |
| 166162 | VC.692/25-SST-p-M5x16  | 25 | 20   | 12             | 10             | M5              | 16 | 9  |
| 166171 | VC.692/25 SST-p-M6x10  | 25 | 20   | 12             | 10             | M6              | 10 | 10 |
| 166172 | VC.692/25 SST-p-M6x16  | 25 | 20   | 12             | 10             | M6              | 16 | 11 |
| 166173 | VC.692/25 SST-p-M6x20  | 25 | 20   | 12             | 10             | M6              | 20 | 12 |
| 166175 | VC.692/25 SST-p-M6x25  | 25 | 20   | 12             | 10             | M6              | 25 | 13 |
| 166174 | VC.692/25 SST-p-M6x30  | 25 | 20   | 12             | 10             | M6              | 30 | 14 |
| 166176 | VC.692/25 SST-p-M6x35  | 25 | 20   | 12             | 10             | M6              | 35 | 15 |
| 166261 | VC.692/32 SST-p-M6x10  | 32 | 22.5 | 14             | 12.5           | M6              | 10 | 17 |
| 166262 | VC.692/32-SST-p-M6x16  | 32 | 22.5 | 14             | 12.5           | M6              | 16 | 15 |
| 166263 | VC.692/32-SST-p-M6x20  | 32 | 22.5 | 14             | 12.5           | M6              | 20 | 16 |
| 166264 | VC.692/32-SST-p-M6x30  | 32 | 22.5 | 14             | 12.5           | M6              | 30 | 19 |
| 166266 | VC.692/32-SST-p-M6x35  | 32 | 22.5 | 14             | 12.5           | M6              | 35 | 20 |
| 166274 | VC.692/32-SST-p-M8x25  | 32 | 22.5 | 14             | 12.5           | M8              | 25 | 21 |
| 166275 | VC.692/32-SST-p-M8x30  | 32 | 22.5 | 14             | 12.5           | M8              | 30 | 22 |
| 166277 | VC.692/32-SST-p-M8x40  | 32 | 22.5 | 14             | 12.5           | M8              | 40 | 23 |
| 166370 | VC.692/40 SST-p-M6x10  | 40 | 26   | 15             | 14             | M6              | 10 | 20 |
| 166372 | VC.692/40 SST-p-M6x20  | 40 | 26   | 15             | 14             | M6              | 20 | 25 |
| 166374 | VC.692/40 SST-p-M6x30  | 40 | 26   | 15             | 14             | M6              | 30 | 27 |
| 166376 | VC.692/40 SST-p-M6x40  | 40 | 26   | 15             | 14             | M6              | 40 | 31 |
| 166379 | VC.692/40 SST-p-M8x16  | 40 | 26   | 15             | 14             | M8              | 16 | 26 |
| 166381 | VC.692/40-SST-p-M8x20  | 40 | 26   | 15             | 14             | M8              | 20 | 28 |
| 166382 | VC.692/40 SST-p-M8x25  | 40 | 26   | 15             | 14             | M8              | 25 | 30 |
| 166383 | VC.692/40-SST-p-M8x30  | 40 | 26   | 15             | 14             | M8              | 30 | 32 |
| 166384 | VC.692/40-SST-p-M8x35  | 40 | 26   | 15             | 14             | M8              | 35 | 34 |
| 166385 | VC.692/40-SST-p-M8x40  | 40 | 26   | 15             | 14             | M8              | 40 | 36 |
| 166386 | VC.692/40-SST-p-M8x45  | 40 | 26   | 15             | 14             | M8              | 45 | 38 |
| 166451 | VC.692/50 SST-p-M8x16  | 50 | 31   | 18             | 17             | M8              | 16 | 38 |
| 166452 | VC.692/50 SST-p-M8x20  | 50 | 31   | 18             | 17             | M8              | 20 | 40 |
| 166453 | VC.692/50 SST-p-M8x25  | 50 | 31   | 18             | 17             | M8              | 25 | 41 |
| 166454 | VC.692/50 SST-p-M8x30  | 50 | 31   | 18             | 17             | M8              | 30 | 42 |
| 166455 | VC.692/50 SST-p-M8x35  | 50 | 31   | 18             | 17             | M8              | 35 | 43 |
| 166456 | VC.692/50 SST-p-M8x40  | 50 | 31   | 18             | 17             | M8              | 40 | 45 |
| 166457 | VC.692/50 SST-p-M8x50  | 50 | 31   | 18             | 17             | M8              | 50 | 46 |
| 166491 | VC.692/50-SST-p-M10x20 | 50 | 31   | 18             | 17             | M10             | 20 | 47 |
| 166493 | VC.692/50-SST-p-M10x30 | 50 | 31   | 18             | 17             | M10             | 30 | 57 |
| 166495 | VC.692/50-SST-p-M10x40 | 50 | 31   | 18             | 17             | M10             | 40 | 67 |
| 166496 | VC.692/50-SST-p-M10x50 | 50 | 31   | 18             | 17             | M10             | 50 | 69 |
| 166562 | VC.692/60 SST-p-M10x20 | 60 | 36.5 | 21             | 21             | M10             | 20 | 70 |
| 166564 | VC.692/60 SST-p-M10x30 | 60 | 36.5 | 21             | 21             | M10             | 30 | 71 |
| 166566 | VC.692/60 SST-p-M10x40 | 60 | 36.5 | 21             | 21             | M10             | 40 | 73 |

|        |                        |    |      |    |    |     |    |    |
|--------|------------------------|----|------|----|----|-----|----|----|
| 166568 | VC.692/60 SST-p-M10x50 | 60 | 36.5 | 21 | 21 | M10 | 50 | 75 |
| 166591 | VC.692/60-SST-p-M12x30 | 60 | 36.5 | 21 | 21 | M12 | 30 | 70 |
| 166593 | VC.692/60-SST-p-M12x40 | 60 | 36.5 | 21 | 21 | M12 | 40 | 81 |
| 166595 | VC.692/60-SST-p-M12x50 | 60 | 36.5 | 21 | 21 | M12 | 50 | 92 |

---



ELESA and GANTER models all rights reserved in accordance with the law. Always mention the source when reproducing our drawings.

**STANDARD MACHINE ELEMENTS WORLDWIDE**